

FM140 LIGHT DUTY SLIDE GUIDE FOR STEEL PIPE		
PART NO.	PIPESIZE	A
FM140-021	15nb	54
FM140-027	20nb	57
FM140-034	25nb	60
FM140-043	32nb	65
FM140-048	40nb	67
FM140-060	50nb	73
FM140-073	65nb	81
FM140-089	80nb	88
FM140-115	100nb	101
FM140-140	125nb	155
FM140-168	150nb	129

FINISH: GALVANISED

FM140 LIGHT DUTY SLIDE GUIDE FOR COPPER PIPE		
PART NO.	PIPESIZE	A
FM140-015	15cu	49
FM140-020	20cu	53
FM140-025	25cu	56
FM140-032	32cu	59
FM140-038	40cu	62
FM140-051	50cu	73
FM140-064	65cu	76
FM140-076	80cu	81
FM140-102	100cu	94
FM140-127	125cu	108
FM140-152	150cu	121

**FINISH: POLYESTER
POWDER COATED**

‘A’ DIMENSION IS A MINIMUM, CAN BE INCREASED TO SUIT INDIVIDUAL ON-SITE REQUIREMENTS



LIGHT DUTY SLIDE GUIDE AND TIMBER FERRULE FOR STEEL PIPE

FM141

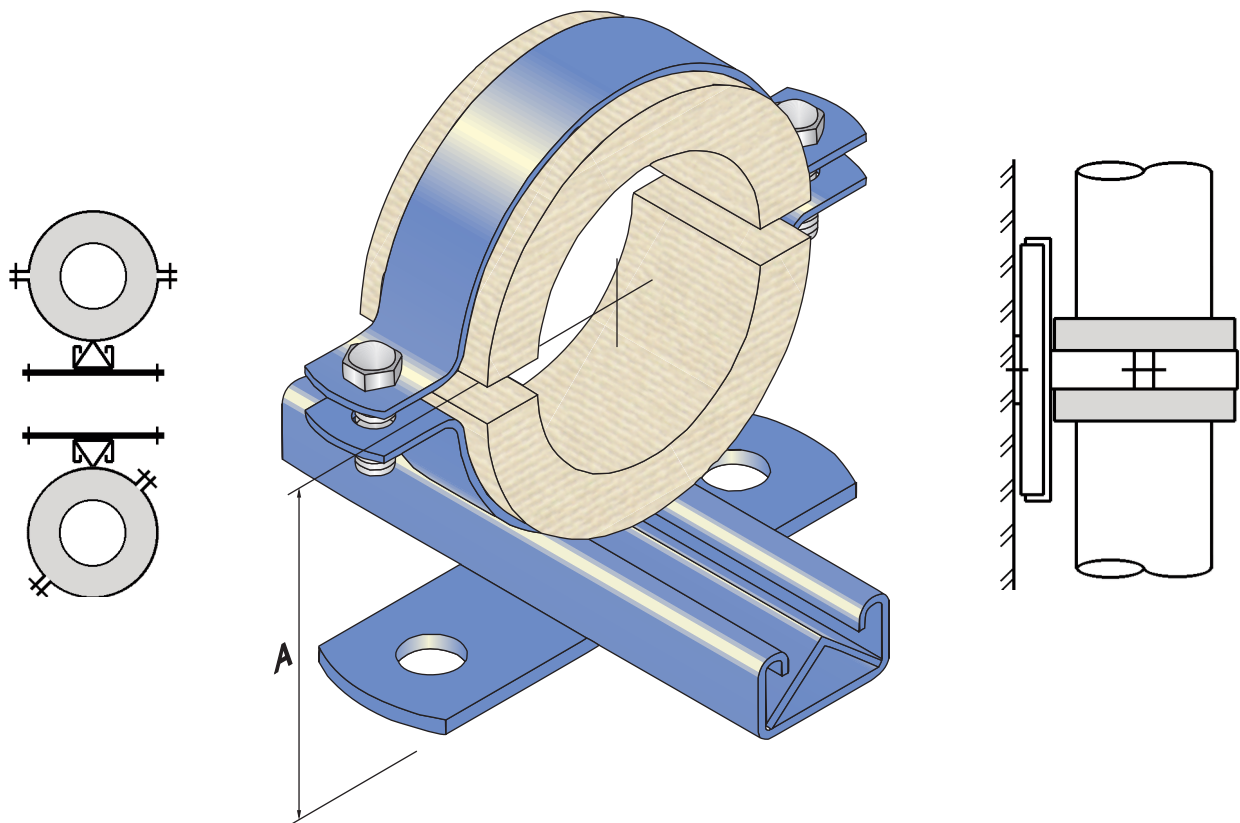

PART NO.	PIPE DIA.	INS.	FERRULE DIA.	A	PART NO.	PIPE DIA.	INS.	FERRULE DIA.	A
FM141-015A	15nb	25	21 x 73	80	FM141-050A	50nb	25	60 x 115	101
FM141-015B		38	21 x 102	94	FM141-050B		38	60 x 140	115
FM141-015C		50	21 x 127	109	FM141-050C		50	60 x 165	128
FM141-020A	20nb	25	27 x 76	80	FM141-065A	65nb	25	73 x 127	109
FM141-020B		38	27 x 102	94	FM141-065B		38	73 x 152	121
FM141-020C		50	27 x 127	109	FM141-065C		50	73 x 178	134
FM141-025A	25nb	25	34 x 83	85	FM141-080A	80nb	25	89 x 140	115
FM141-025B		38	34 x 115	101	FM141-080B		38	89 x 165	128
FM141-025C		50	34 x 140	115	FM141-080C		50	89 x 190	140
FM141-032A	32nb	25	43 x 89	88	FM141-100A	100nb	25	115 x 165	128
FM141-032B		38	43 x 115	101	FM141-100B		38	115 x 190	140
FM141-032C		50	43 x 140	115	FM141-100C		50	115 x 220	155
FM141-040A	40nb	25	48 x 102	94					
FM141-040B		38	48 x 127	109					
FM141-040C		50	48 x 152	121					

FINISH: GALVANISED

'A' DIMENSION IS A MINIMUM, CAN BE INCREASED TO SUIT INDIVIDUAL ON-SITE REQUIREMENTS

FM141

LIGHT DUTY SLIDE GUIDE AND FERRULE FOR COPPER PIPE

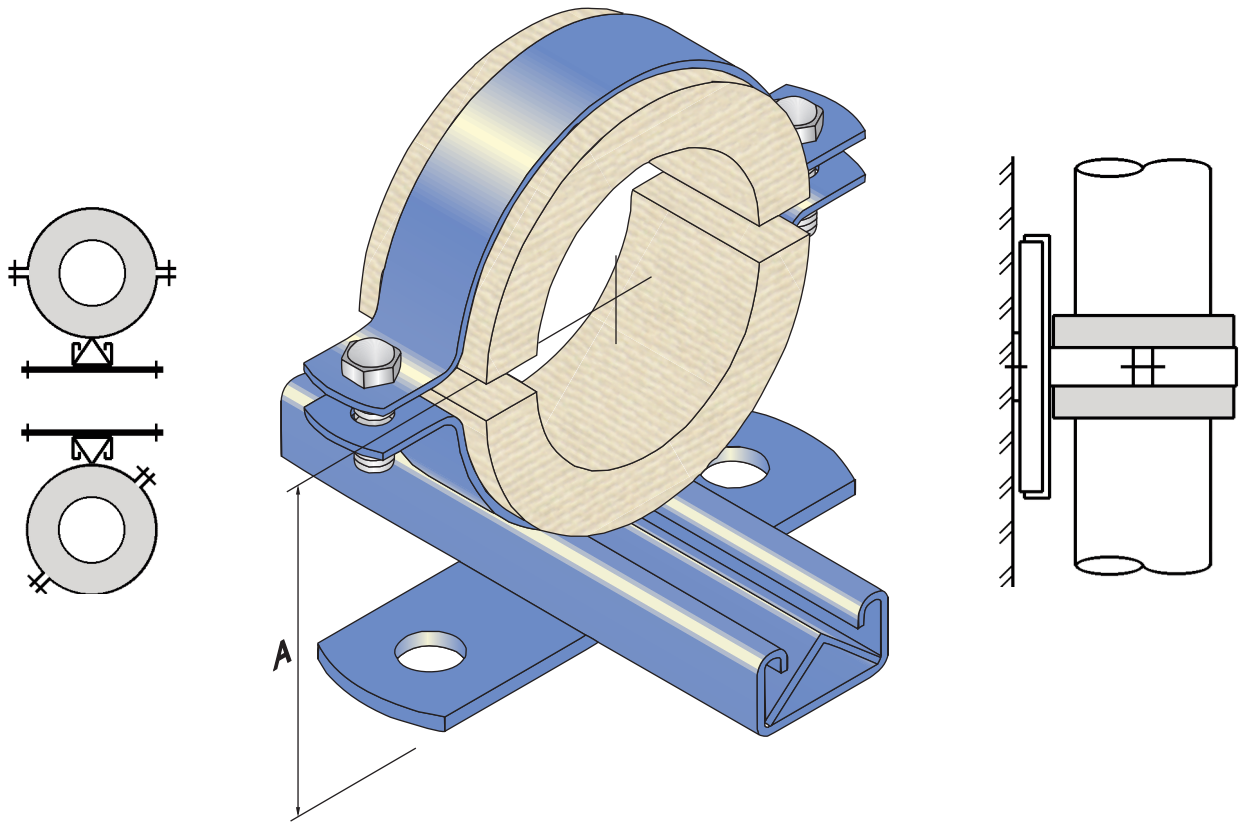

PART NO.	PIPE DIA.	INS.	FERRULE DIA.	A	PART NO.	PIPE DIA.	INS.	FERRULE DIA.	A
FM141-015D	15cu	25	13 x 65	76	FM141-050D	50cu	25	51 x 102	94
FM141-015E		38	13 x 89	88	FM141-050E		38	51 x 127	109
FM141-015F		50	13 x 115	101	FM141-050F		50	51 x 152	121
FM141-020D	20cu	25	19 x 70	78	FM141-065D	65cu	25	65 x 115	101
FM141-020E		38	19 x 102	94	FM141-065E		38	65 x 140	115
FM141-020F		50	19 x 127	109	FM141-065F		50	65 x 165	128
FM141-025D	25cu	25	25 x 76	80	FM141-080D	80cu	25	76 x 127	109
FM141-025E		38	25 x 102	94	FM141-080E		38	76 x 152	121
FM141-025F		50	25 x 127	109	FM141-080F		50	76 x 178	134
FM141-032D	32cu	25	32 x 83	85	FM141-100D	100cu	25	102 x 152	121
FM141-032E		38	32 x 115	101	FM141-100E		38	102 x 178	134
FM141-032F		50	32 x 140	115	FM141-100F		50	102 x 203	147
FM141-040D	40cu	25	38 x 89	88					
FM141-040E		38	38 x 115	101					
FM141-040F		50	38 x 140	115					

FINISH: GALVANISED

'A' DIMENSION IS A MINIMUM, CAN BE INCREASED TO SUIT INDIVIDUAL ON-SITE REQUIREMENTS



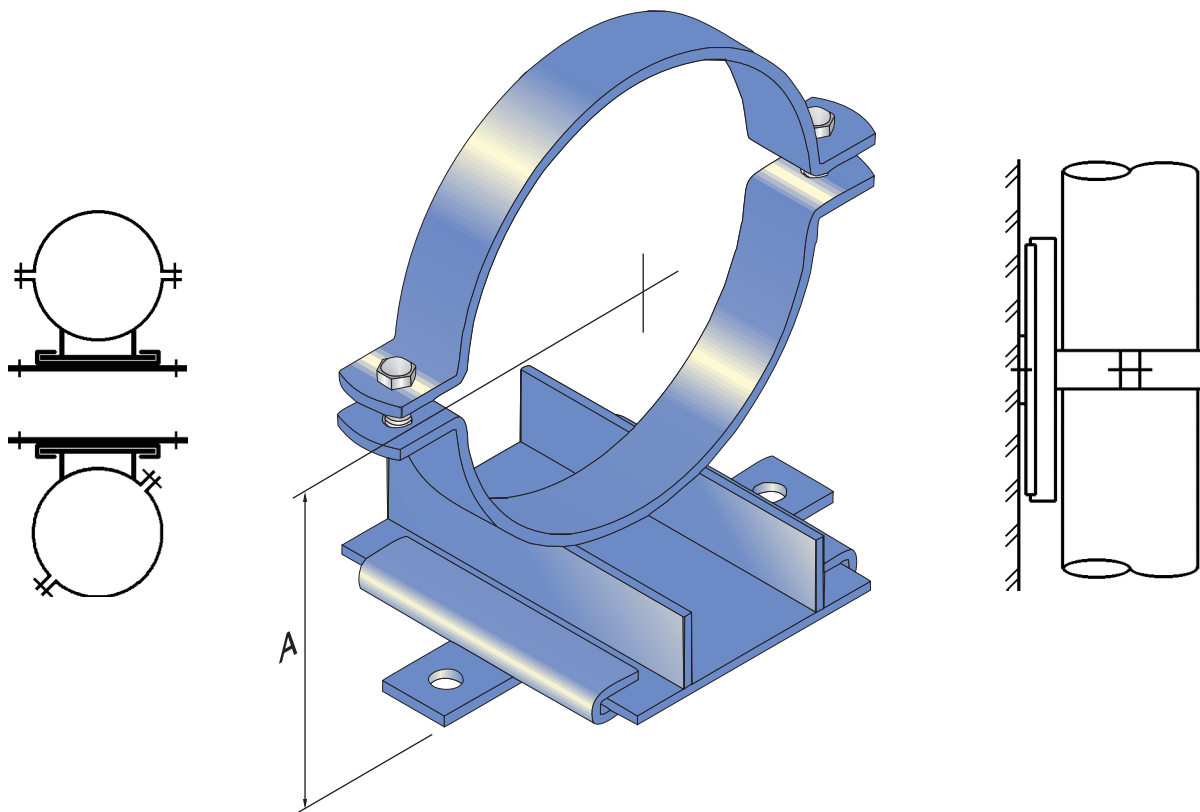

FM142 HEAVY DUTY SLIDE GUIDE FOR STEEL PIPE		
PART NO.	PIPESIZE	A
FM142-168	150nb	142
FM142-220	200nb	168
FM142-273	250nb	195
FM142-324	300nb	242
FM142-355	350nb	258
FM142-406	400nb	283
FM142-506	500nb	333
FM142-610	600nb	385

FINISH: GALVANISED

FM142 HEAVY DUTY SLIDE GUIDE FOR COPPER PIPE		
PART NO.	PIPESIZE	A
FM142-152	150cu	134
FM142-203	200cu	160
FM142-254	250cu	185
FM142-304	300cu	210

**FINISH: POLYESTER
POWDER COATED**

‘A’ DIMENSION IS A MINIMUM, CAN BE INCREASED TO SUIT INDIVIDUAL ON-SITE REQUIREMENTS

FM143

HEAVY DUTY SLIDE GUIDE AND TIMBER FERRULE FOR STEEL PIPE

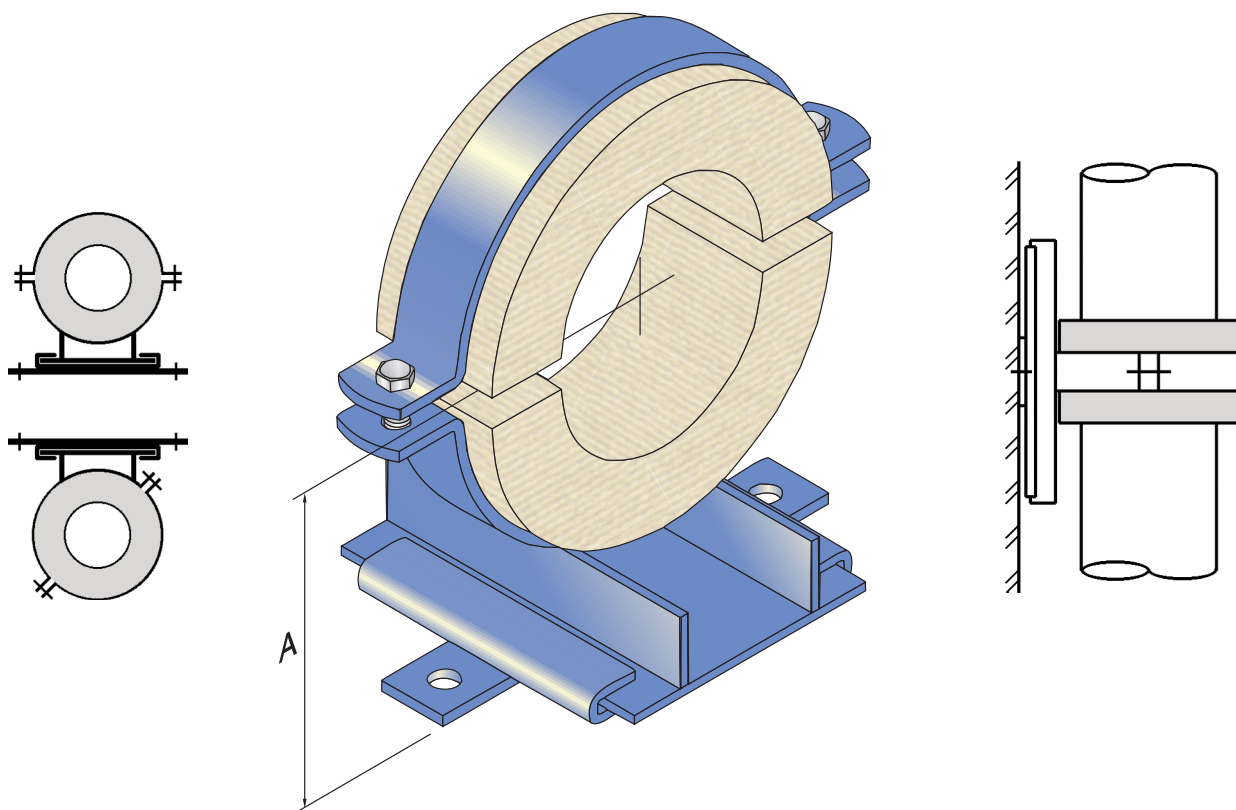

PART NO.	PIPE DIA.	INS.	FERRULE DIA.	A	PART NO.	PIPE DIA.	INS.	FERRULE DIA.	A
FM143-125A	125nb	25	140 x 190	153	FM143-300A	300nb	25	324 x 375	268
FM143-125B		38	140 x 220	168	FM143-300B		38	324 x 406	283
FM143-125C		50	140 x 240	178	FM143-300C		50	324 x 424	292
FM143-150A	150nb	25	168 x 220	168	FM143-350A	350nb	25	355 x 406	283
FM143-150B		38	168 x 240	178	FM143-350B		38	355 x 424	292
FM143-150C		50	168 x 268	192	FM143-350C		50	355 x 457	309
FM143-200A	200nb	25	220 x 275	196	FM143-400A	400nb	25	406 x 457	309
FM143-200B		38	220 x 300	208	FM143-400B		38	406 x 483	321
FM143-200C		50	220 x 324	220	FM143-400C		50	406 x 508	334
FM143-250A	250nb	25	273 x 324	220	FM143-450A	450nb	25	455 x 508	334
FM143-250B		38	273 x 356	236	FM143-450B		38	455 x 533	347
FM143-250C		50	273 x 375	246	FM143-450C		50	455 x 557	359

FINISH: GALVANISED

'A' DIMENSION IS A MINIMUM, CAN BE INCREASED TO SUIT INDIVIDUAL ON-SITE REQUIREMENTS



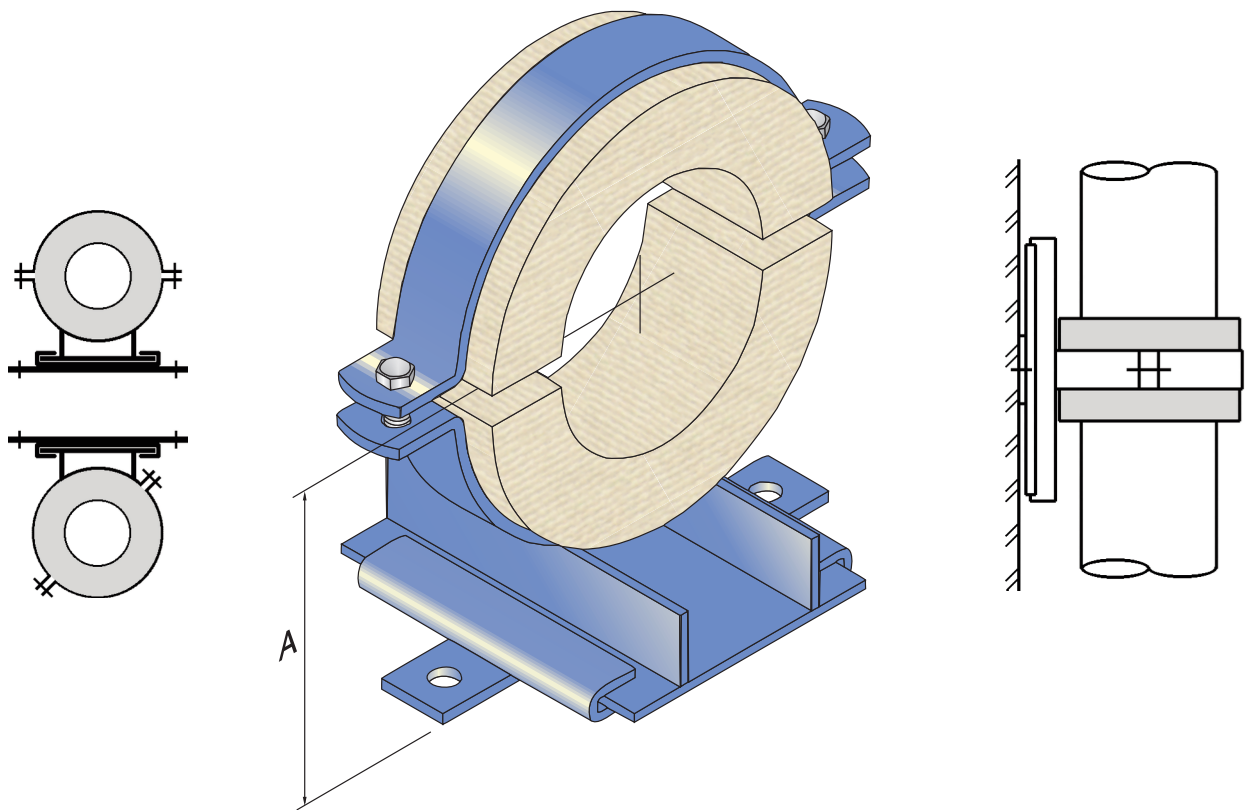

PART NO.	PIPE DIA.	INS.	FERRULE DIA.	A
FM143-125D	125cu	25	127 x 178	147
FM143-125E		38	127 x 203	160
FM143-125F		50	127 x 228	172
FM143-150D	150cu	25	152 x 203	160
FM143-150E		38	152 x 228	172
FM143-150F		50	152 x 252	184
FM143-200D	200cu	25	203 x 252	184
FM143-200E		38	203 x 275	196
FM143-200F		50	203 x 300	208
FM143-250D	250cu	25	254 x 300	208
FM143-250E		38	254 x 330	223
FM143-250F		50	254 x 355	236

FINISH: GALVANISED

'A' DIMENSION IS A MINIMUM, CAN BE INCREASED TO SUIT INDIVIDUAL ON-SITE REQUIREMENTS

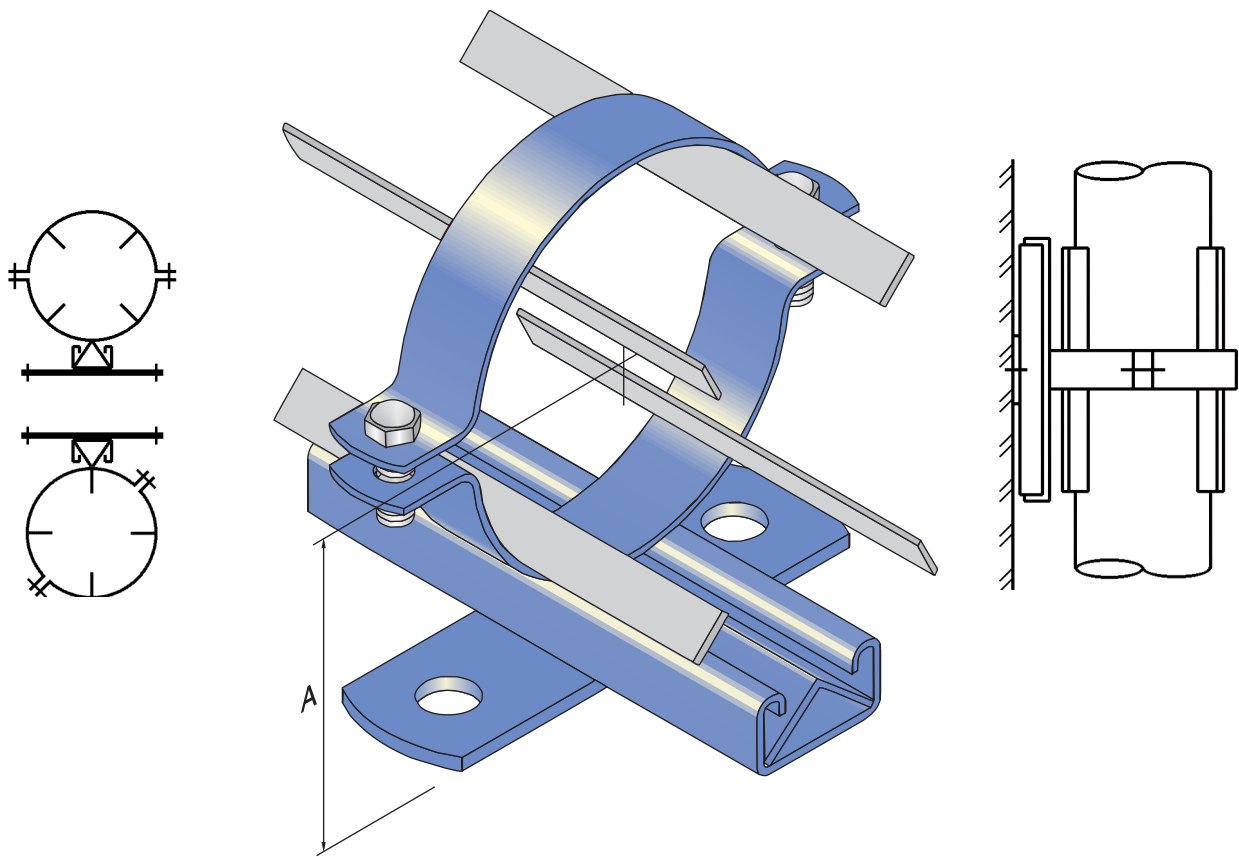

PART NO.	PIPE DIA.	INS.	SIZE	A
FM144-015A	15nb	25	21 x 73	80
FM144-015B		38	21 x 102	94
FM144-015C		50	21 x 127	109
FM144-020A	20nb	25	27 x 76	80
FM144-020B		38	27 x 102	94
FM144-020C		50	27 x 127	109
FM144-025A	25nb	25	34 x 83	85
FM144-025B		38	34 x 115	101
FM144-025C		50	34 x 140	115
FM144-032A	32nb	25	43 x 89	88
FM144-032B		38	43 x 115	101
FM144-032C		50	43 x 140	115
FM144-040A	40nb	25	48 x 102	94
FM144-040B		38	48 x 127	109
FM144-040C		50	48 x 152	121

PART NO.	PIPE DIA.	INS.	SIZE	A
FM144-050A	50nb	25	60 x 115	101
FM144-050B		38	60 x 140	115
FM144-050C		50	60 x 165	128
FM144-065A	65nb	25	73 x 127	109
FM144-065B		38	73 x 152	121
FM144-065C		50	73 x 178	134
FM144-080A	80nb	25	89 x 140	115
FM144-080B		38	89 x 165	128
FM144-080C		50	89 x 190	140
FM144-100A	100nb	25	115 x 165	128
FM144-100B		38	115 x 190	140
FM144-100C		50	115 x 220	155

FINISH: GALVANISED

'A' DIMENSION IS A MINIMUM, CAN BE INCREASED TO SUIT INDIVIDUAL ON-SITE REQUIREMENTS



LIGHT DUTY SLIDE GUIDE FOR STEAM & CONDENSATE COPPER PIPE **FM144**

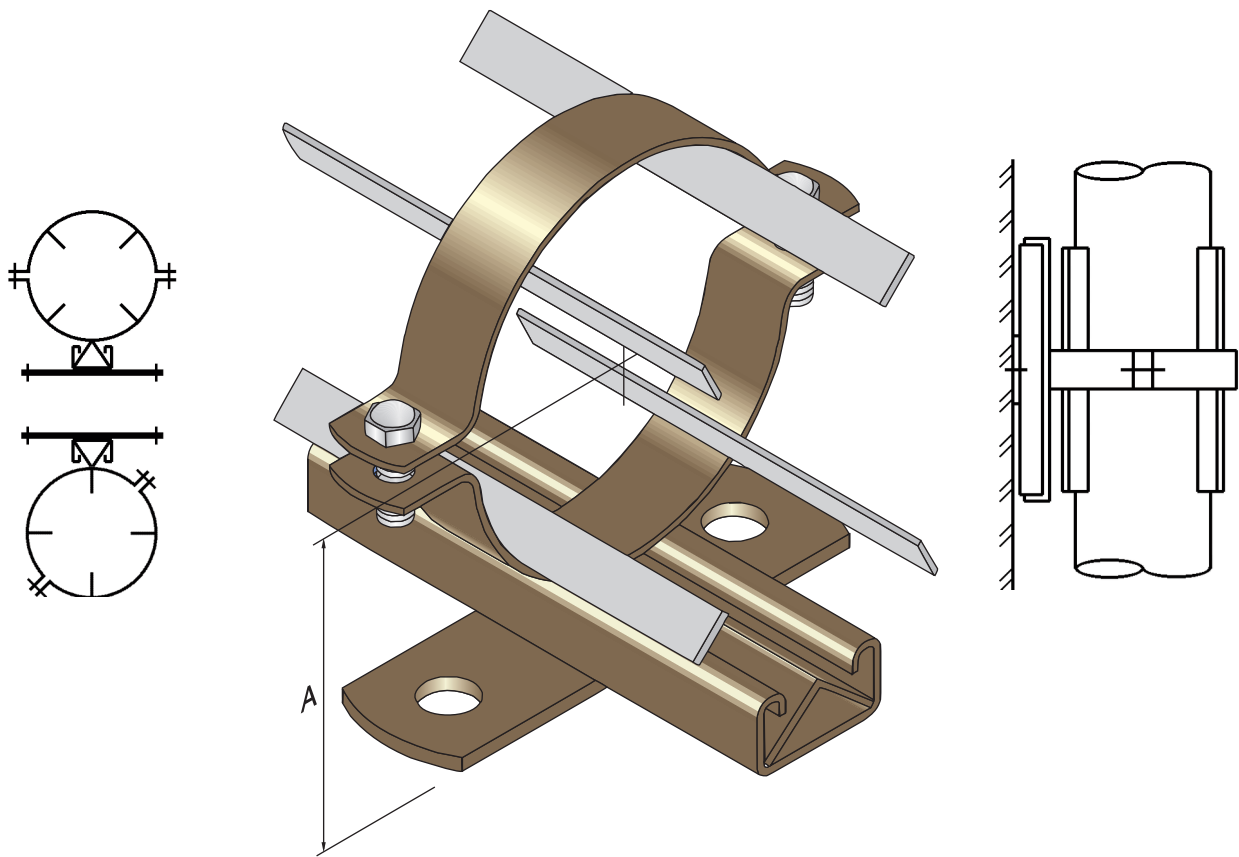

PART NO.	PIPE DIA.	INS.	SIZE	A	PART NO.	PIPE DIA.	INS.	SIZE	A
FM144-015D	15cu	25	13 x 65	76	FM144-050D	50cu	25	51 x 102	94
FM144-015E		38	13 x 89	88	FM144-050E		38	51 x 127	109
FM144-015F		50	13 x 115	101	FM144-050F		50	51 x 152	121
FM144-020D	20cu	25	19 x 70	78	FM144-065D	65cu	25	65 x 115	101
FM144-020E		38	19 x 102	94	FM144-065E		38	65 x 140	115
FM144-020F		50	19 x 127	109	FM144-065F		50	65 x 165	128
FM144-025D	25cu	25	25 x 76	80	FM144-080D	80cu	25	76 x 127	109
FM144-025E		38	25 x 102	94	FM144-080E		38	76 x 152	121
FM144-025F		50	25 x 127	109	FM144-080F		50	76 x 178	134
FM144-032D	32cu	25	32 x 83	85	FM144-100D	100cu	25	102 x 152	121
FM144-032E		38	32 x 115	101	FM144-100E		38	102 x 178	134
FM144-032F		50	32 x 140	115	FM144-100F		50	102 x 203	147
FM144-040D	40cu	25	38 x 89	88					
FM144-040E		38	38 x 115	101					
FM144-040F		50	38 x 140	115					

FINISH: POLYESTER POWDER COATED

'A' DIMENSION IS A MINIMUM, CAN BE INCREASED TO SUIT INDIVIDUAL ON-SITE REQUIREMENTS



FM145

HEAVY DUTY SLIDE GUIDE FOR STEAM & CONDENSATE STEEL PIPE

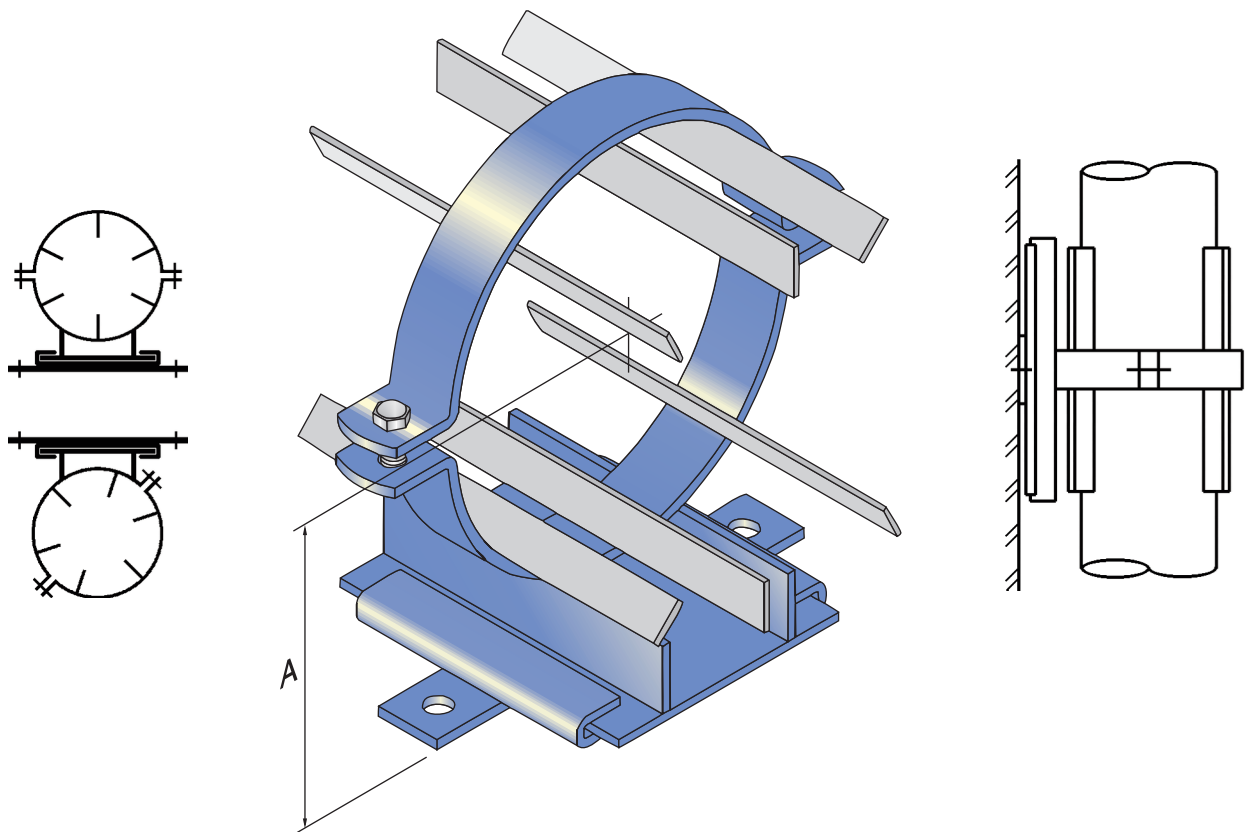

PART NO.	PIPE DIA.	INS.	SIZE	A	PART NO.	PIPE DIA.	INS.	SIZE	A
FM145-125A	125nb	25	140 x 190	153	FM145-300A	300nb	25	324 x 375	268
FM145-125B		38	140 x 220	168	FM145-300B		38	324 x 406	283
FM145-125C		50	140 x 240	178	FM145-300C		50	324 x 424	292
FM145-150A	150nb	25	168 x 220	168	FM145-350A	350nb	25	355 x 406	283
FM145-150B		38	168 x 240	178	FM145-350B		38	355 x 424	292
FM145-150C		50	168 x 268	192	FM145-350C		50	355 x 457	309
FM145-200A	200nb	25	220 x 275	196	FM145-400A	400nb	25	406 x 457	309
FM145-200B		38	220 x 300	208	FM145-400B		38	406 x 483	321
FM145-200C		50	220 x 324	220	FM145-400C		50	406 x 508	334
FM145-250A	250nb	25	273 x 324	220	FM145-450A	450nb	25	455 x 508	334
FM145-250B		38	273 x 356	236	FM145-450B		38	455 x 533	347
FM145-250C		50	273 x 375	246	FM145-450C		50	455 x 557	359

FINISH: GALVANISED

'A' DIMENSION IS A MINIMUM, CAN BE INCREASED TO SUIT INDIVIDUAL ON-SITE REQUIREMENTS



HEAVY DUTY SLIDE GUIDE FOR STEAM & CONDENSATE COPPER PIPE **FM145**

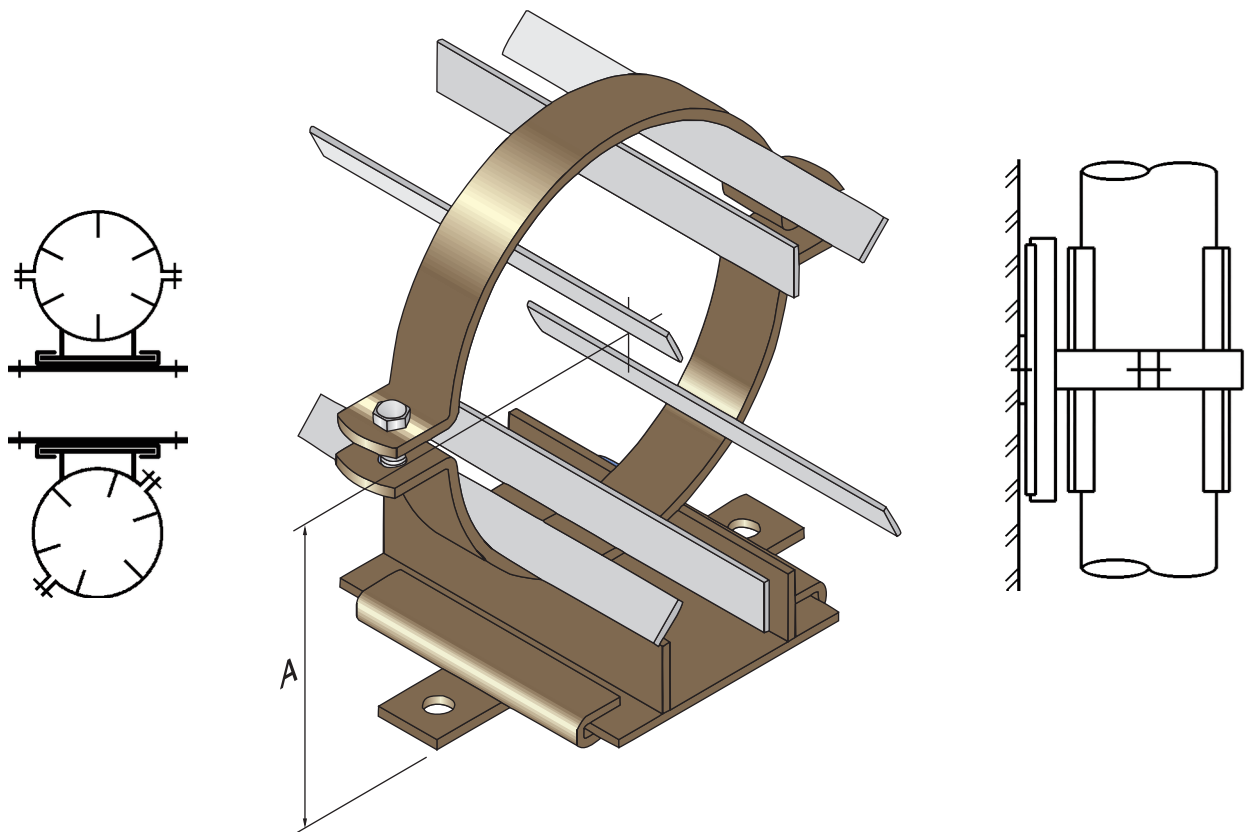

PART NO.	PIPE DIA.	INS.	SIZE	A
FM145-125D	125cu	25	127 x 178	147
FM145-125E		38	127 x 203	160
FM145-125F		50	127 x 228	172
FM145-150D	150cu	25	152 x 203	160
FM145-150E		38	152 x 228	172
FM145-150F		50	152 x 252	184
FM145-200D	200cu	25	203 x 252	184
FM145-200E		38	203 x 275	196
FM145-200F		50	203 x 300	208
FM145-250D	250cu	25	254 x 300	208
FM145-250E		38	254 x 330	223
FM145-250F		50	254 x 355	236

FINISH: POLYESTER POWDER COATED

'A' DIMENSION IS A MINIMUM, CAN BE INCREASED TO SUIT INDIVIDUAL ON-SITE REQUIREMENTS