

**FM193
PIPE SPIDER**

FINISH: PLAIN OR GALVANISED

SPECIFY I.D. x O.D. x LENGTH

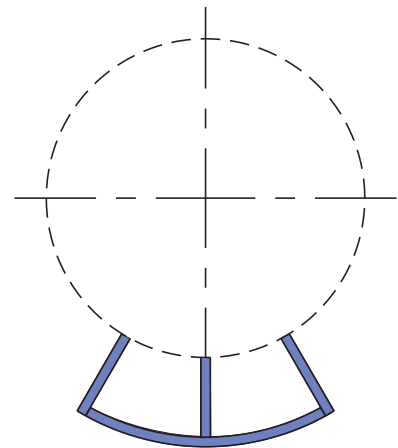

**FM194
PIPE ROLLERS**

ADJUSTABLE FOR PIPES 15nb TO 150nb

**FINISH: ROLLERS - CAST IRON
BRACKETS - Z.P.**

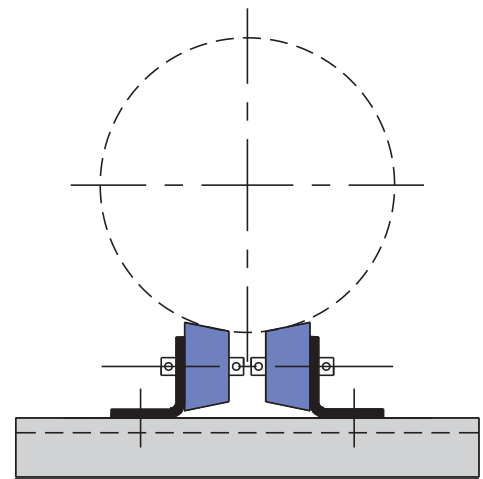

**FM195
PIPE ROLLER ASSEMBLY**

| PART NO. | PIPE DIA. |
|----------|----------------|
| FM195-1 | TO 125nb |
| FM195-2 | 125nb TO 200nb |
| FM195-3 | 200nb TO 300nb |
| FM195-4 | 300nb TO 400nb |

**FINISH: ROLLERS - CAST IRON
BRACKETS - Z.P.**

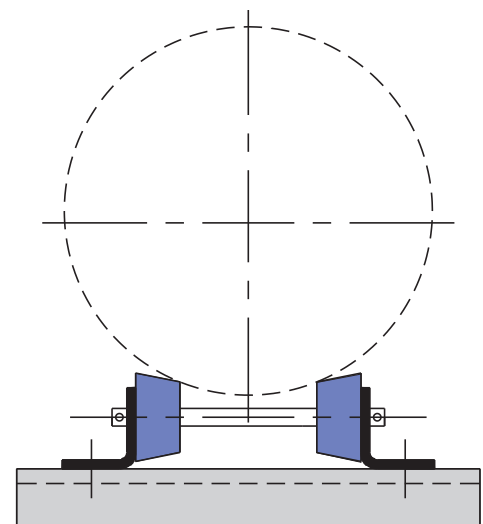

FM196
FM197

PIPE ROLLERS

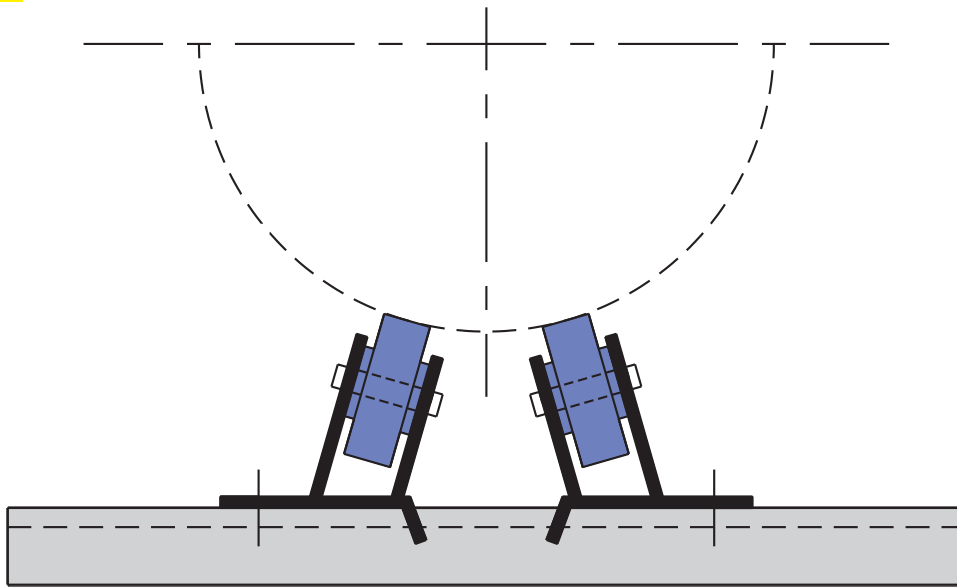

FM196
PIPE ROLLERS **ADJUSTABLE FOR PIPES 150nb TO 450nb**
FINISH: ROLLERS - CAST IRON BRACKETS - Z.P.

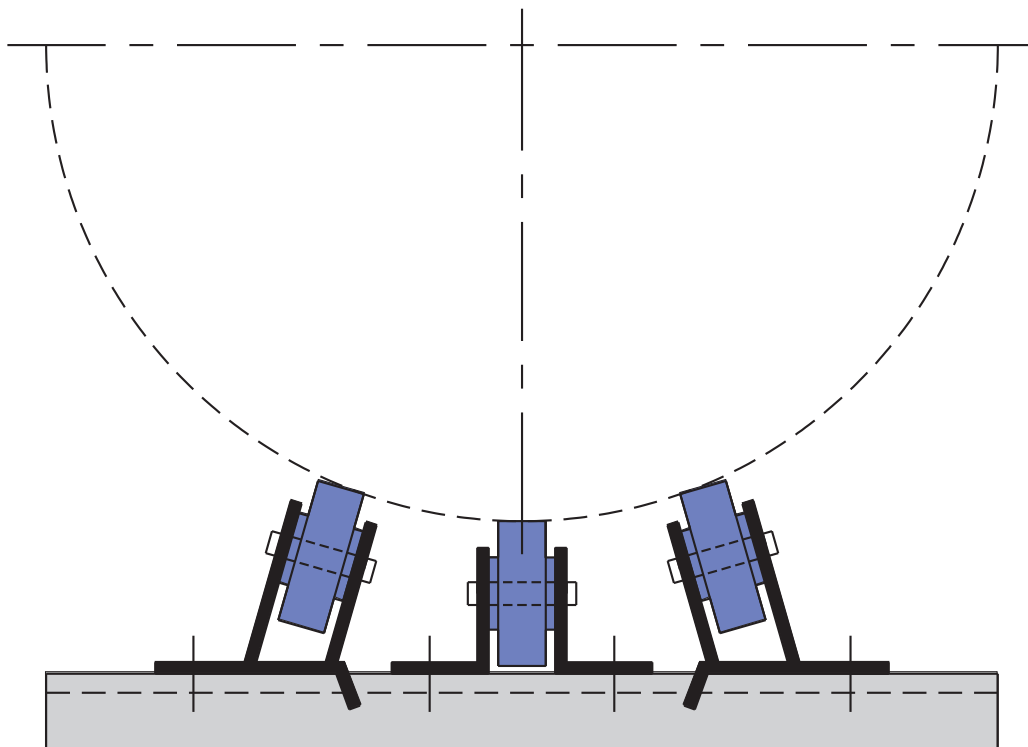

FM197
PIPE ROLLERS **ADJUSTABLE FOR PIPES 400nb TO 600nb**
FINISH: ROLLERS - CAST IRON BRACKETS - Z.P.

