

FM151
FM152
FM153
FM154

**EYEBOLTS AND SPHERICAL WASHERS
 CLEVIS AND BLADE ENDS**

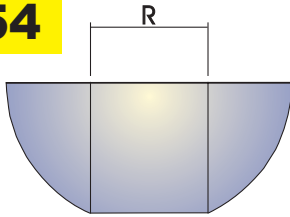

FM152 SPHERICAL WASHER	
PART NO.	R
FM152-M10	11
FM152-M12	14
FM152-M16	18
FM152-M20	22
FM152-M24	26
FM152-M30	32
FM152-M36	38

**FINISH: GALVANISED
 OR PLAIN**

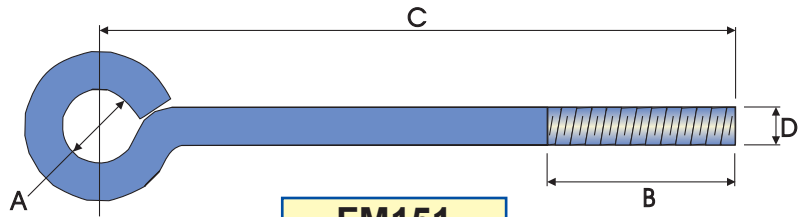

**FM151
EYEBOLT**

**ALL DIMENSIONS TO ORDER.
 FINISH: GALVANISED, PAINTED OR PLAIN**

FM153 HANGER CLEVIS				
PART NO	C	D1	D2	W x t
FM153-M10 LD	70	11	11	25 x 3
FM153-M10	70	11	11	25 x 5
FM153-M12	75	14	14	40 x 6
FM153-M16	100	18	14	50 x 6
FM153-M20	112	22	22	75 x 10

FINISH: GALVANISED

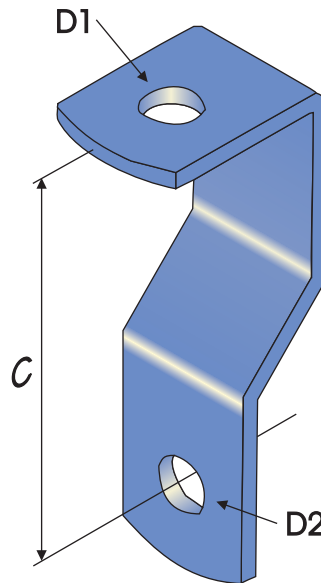

FM154 BLADE END HANGER						
PART NO	ROD DIA.	A	B	C	H	MAT.
FM154-M10	10	60	15	25	12	25 x 5
FM154-M12	12	70	22	32	14	40 x 6
FM154-M16	16	80	25	32	18	75 x 10
FM154-M20	20	90	32	35	22	90 x 12
FM154-M24	24	90	32	35	26	90 x 12

FINISH: GALVANISED OR PLAIN

